

We share your passion!

Drop TT

Item: BAKDRPTT

Table top gearwheel depositor for the production of soft batter products like macarons, eclairs, choux, cupcakes and muffins.

Key Features

Compact
Easy to clean
Accurate
Color touchscreen (English, French and Spanish)
Hopper capacity: 50 lbs.
Speed: 2 trays per min. depending on product

Applications

French Macarons, Eclairs, Choux, Cupcakes and Muffins

Benefits

Ease of use
Ease of cleaning
Minimum space (foldable conveyor)
Fast and accurate

Options

Rotary nozzles
Cart



Technical Specifications

Power: 1.4 kW
220V/ 60 Hz
For standard US Trays (18 in. by 26in.)
Weight: 330 lbs.
Dimensions: 44 1/4in. (L) x 35in.(W) x 30in. (H) (when conveyor closed, (L) is 27in.) - see attached dimensional drawings.



We share your passion!

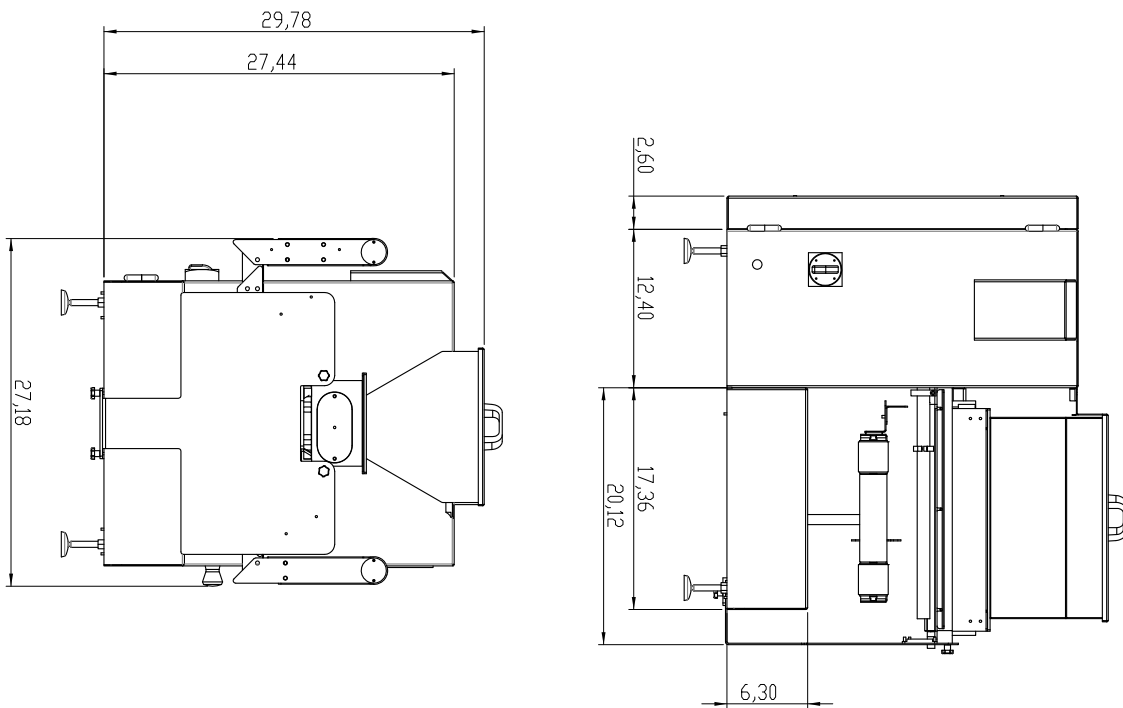
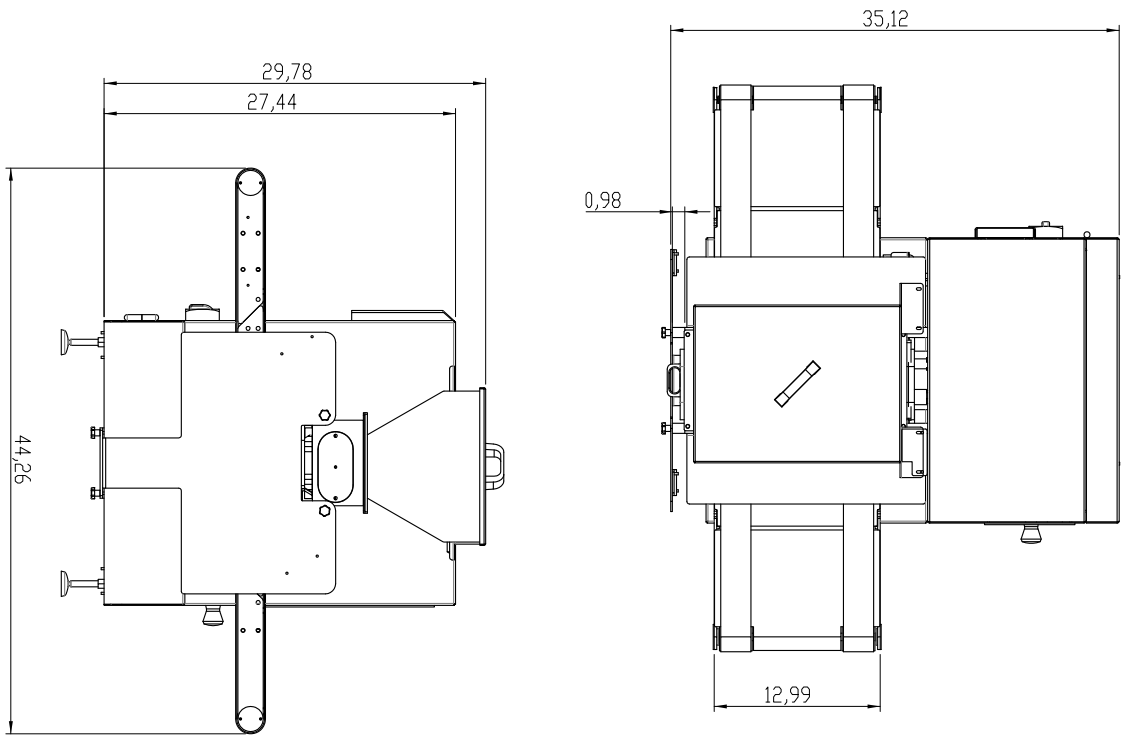

For more information, please call 310-533-3939
www.bakonusa.com